

TPC



strumentidentali.it

#PC-2530 - Mobile-Vac Portable Evacuation Unit

OPERATION MANUAL

TPC *Advanced Technology, Inc.*

Sold through authorized dealers only

Disclaimer

Congratulations on the purchase of your new PC-2530 Mobile-vac Portable Evacuation Unit. To get the maximum benefit from your unit, please read these instructions before making any adjustments, and retain them for future reference. We hope you will experience many years of enjoyment from your new evacuation system.

For further assistance, please call: 800-560-8222 or visit our website: www.tpcdental.com

Purchase Date: _____

From Authorized Dealer: _____

Warranty, Terms & Conditions

The PC-2530 Mobile-vac Portable Evacuation Unit comes with a 1-year warranty. Under standard TPC Terms & Conditions, a user has 7-day from the delivery of the unit to return for a full refund. Shipping is not covered under warranty. If you experience any difficulties or need help troubleshooting the unit please call your authorized TPC Dental Technician or our technical support line at 800-560-8222; otherwise please visit our website for additional information: <http://www.tpcdental.com/terms.html>

Unit is warranted for one year from date of manufacture as determined by the serial number on the product label. Labels are generated and applied to the product at the time of shipment. TPC warrants its product(s) to the original purchaser and in the case of original equipment manufacturers, to their original customer to be free from defects in material and workmanship and to be made only in accordance with TPC's standard published catalog specifications for the product(s) as published at the time of purchase. Warranty or performance to any other specifications is not covered by this warranty unless otherwise agreed to in writing by TPC and documented as part of any and all contracts, including but not limited to purchase orders, sales orders, order confirmations, purchase contracts and purchase agreements. In no event shall TPC be liable or have any responsibility under such warranty if the product(s) has been improperly stored, installed, used or maintained, or if Buyer has permitted any unauthorized modifications, adjustments and/or repairs to such product(s). Seller's obligation hereunder is limited solely to repairing or replacing (at its opinion), at the factory any product(s), or parts thereof, which prove to Seller's satisfaction to be defective as a result of defective materials, or workmanship and within the period of time, in accordance

with the Seller's stated product warranty (see Terms and Conditions above), provided. The product(s) claimed to be defective must be returned to TPC, transportation prepaid by Buyer, with written specification of the claimed defect. Evidence acceptable to TPC must be furnished that the claimed defects were not caused by misuse, abuse, or neglect by anyone other than TPC.

Any components considered wear parts and must be inspected and serviced on a regular basis. Any damage due to excessive loading is not covered by this warranty. The use of unit or components under load such that they reach the end of their expected life is a normal characteristic of the application of mechanical products. Reaching the end of a product's expected life does not indicate any defect in material or workmanship and is not covered by this warranty. The use of unit under parameters outside normal operating conditions is not covered by this warranty.

Costs for shipment of units returned to the factory for warranty repairs are the responsibility of the owner of the product. TPC will return ship all warranty repairs or replacements via UPS Ground at no cost to the customer.

Seller's maximum liability with respect to these terms and conditions and any resulting sale, arising from any cause whatsoever, including without limitation, breach of contract or negligence, shall not exceed the price specified herein of the product(s) giving rise to the claim, and in no event shall TPC be liable under this warranty otherwise for special, incidental or consequential damages, whether similar or dissimilar, of any nature arising or resulting from the purchase, installation, removal, repair, operation, use or breakdown of the product(s) or any other cause whatsoever, including negligence.

The foregoing warranty shall also apply to products or parts which have been repaired or replaced pursuant to such warranty, and within the period of time, in accordance with Seller's stated warranty.

NO PERSON INCLUDING ANY AGENT OR REPRESENTATIVE OF TPC, IS AUTHORIZED TO MAKE ANY REPRESENTATION OR WARRANTY ON BEHALF OF TPC CONCERNING ANY PRODUCTS MANUFACTURED BY TOC, EXCEPT TO REFER PURCHASERS TO THIS WARRANTY.

Copyright, this manual, other accessories of this product or product documentation is owned and all rights were reserved by TPC.

Manual Symbols:



Note: There are likely to lose parts and material document



Note: That can damage equipment or cause equipment not working properly

Marginal data:



Consult Instructions for use



Protective Earth

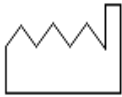

On



Off



strumentidentali.it

Date of Manufacturer

Contents

1. Brief introduction
2. Technical Parameter
3. The Equipment Structure
4. Functions of main parts
5. Maintenance
6. Split-up drawing of ring blower
7. Troubleshooting
8. Working principle overview
9. Safety precautions
10. Drawing of air connection and electrical circuit
11. External mark and content
12. Packing list

strumentidentali.it

1. Brief introduction

Thank you for purchasing the PC-2530; it is our pleasure to bring you a multipurpose electro-mechanically integrated unit that is energy efficient, portable, safe and maintenance free unit. Please read the following manual to better operate your unit.

1.1 Contents of the manual

The operation manual includes brief introduction, technical data, installation and test, maintenance, split-up drawing of ring blower and so on. You can get help in according to the contents.

1.2 Performance and structure

The dental suction unit consists of drain bottle, filter, ring blower, DC water pump and case.

1.3 Usage

The suction unit is applied in the process of oral cavity treatment as it can pump foreign objects attached with germina, such as oral secretion and dirty blood, as well as protecting environment since the objects can be dealt with before being pumped. It is mainly used for clinics and hospitals in the treatment of oral health.

1.4 Safety Information

1.4.1 Electric safety

- To make sure that the plug of this unit is three-phase with good grounding.
- Before connecting the power plug, please ensure the rated voltage consistent with the named voltage which this unit required.
- To avoid unsteady voltage, please do not use the power plug together with other electric equipment.
- Before maintaining or repairing the unit, please unplug that electric wire firstly.
- Please check the electric wire and plug regularly to avoid the damage or extrusions.

1.4.2 Cleaning

Please keep the environment around the product clean, and note to unplug that electric wire before cleaning the unit.

The process of cleaning as follows: firstly wipe the outer surface with a soft cloth stained with neutral detergent, and then use a soft cloth to clean the machine again.

Notice: Do not use liquid or detergent containing flammable substances.

1.4.3 Other safety information

When using this unit, please strictly operate it in according to the following rules:

1) Please note that the power plug is designed as the safety device, not power switch. It is necessary to ensure the power plug can be unplugged from the plug without extrusions.

Warning: The good grounding is necessary to avoid the risk of electric shock.

2) Equipment cannot be used in flammable mixture environment.

3) Equipment cannot be used in anesthetic and air, oxygen, nitrogen mixture environment.

4) Don't put the equipment together with oxygen cylinder.

5) Please do not operate the equipment or replace the accessories when the following situations occur:

- Damage of the power plug
- Equipment cannot work normally
- Breakdown of the equipment
- Water inlet of the equipment
- Loud or shrill noise, overheated outlet air or foul smells during operation.

When above situations occur, please contact the manufacturer or local agent. In order to be convenient for us to offer after sale service, please offer drawing of electrical circuit, air and water connection diagram, packing list and other useful information when necessary.

6) Please use original or qualified disinfectant.

7) Turn off the power when the operator left.

8) Dispose of waste liquid and waste solid according to the local health regulations.

9) Do not use and store the equipment outside the specified environment.

10) Keep accessories from dropping to avoid damages.

11) Keep the electric wire from losing in the process of treatment.

12) Please use accessories from original manufacturer.

13) Keep the equipment in a solid and horizontal level.

1.5 Product information

Name: Medical Suction Unit

Model: DSxxxxxx

Configuration: refer to enclosed Packing List

Models of dental suction units: DS3701CS、DS3701CS-1、DS7501CS、DS3701M、DS2501M。

1.6 Edition information

Operation Manual Number:DL-DS –EG-1401-01.

2. Technical data

2.1 Product data:

No.	Model	Voltage	Power (VA)	Air flow (L/min)	Maximum negative pressure (Kpa)	Noise(dB)	Specification of overload protector (A)
1.	DS3701CS	AC110-230 V 50/60Hz	600	350	-11	≤75	8
2.	DS7501CS	AC110-230 V 50/60Hz	1200	700	-17	≤75	20
3.	DS3701CS-1	AC110-230 V 50/60Hz	600	350	-11	≤75	8
4.	DS3701M	AC110-230 V 50/60Hz	600	350	-11	≤75	8
5.	DS2501M	AC110-230 V 50/60Hz	500	250	-8	≤75	6



Warning:

Please operate the unit strictly under the rated supply voltage, because the unsteady current can cause injuries to the unit.

Please install power voltage regulator when supply voltage is unsteady, and the rated power is no less than 4000VA.

2.2 Product Classification

2.2.1 Classification of air flow: High volume suction system

2.2.2 Classification of suction method: semi-dry system

2.2.3 Classification of dental equipments management: Oral equipments and instruments (code6855), Type 1 management

2.2.4 Classification of electric shock protection: Type I equipment.

2.2.5 Degree of Protection against electric shock: Type B equipment.

2.2.6 Classification of waterproof: Normal equipment (IP20).

2.2.7 Classification of working frequency: intermittent duty.

2.3 Transportation, storage and condition of usage

2.3.1 Condition of transportation

The machine should be transported according to specific requirements of signed contract.

2.3.2 Condition of storage

The machine should be stored in the place with relative humidity not greater than 80%. Surrounding area of the machine should be clean, dry, and free of corrective gas, well ventilated and indirect sunlight.

2.3.2 Condition of usage

Ambient temperature: 5℃~40℃

Relative humidity: ≤80%

Atmosphere pressure: 86Kpa ~106Kpa

Warning: The unit cannot be used in an area where the air is contaminated with the flammable anesthetic, which the explosion may occur.

2.4 Condition of installation

Installing the machine in a solid and horizontal level with, and does not have an incline greater than 2°.

2.5 Condition of power

Voltage range: AC110-220V 50/60Hz

3. The Equipment Structure

3.1.1 DS3701CS structure



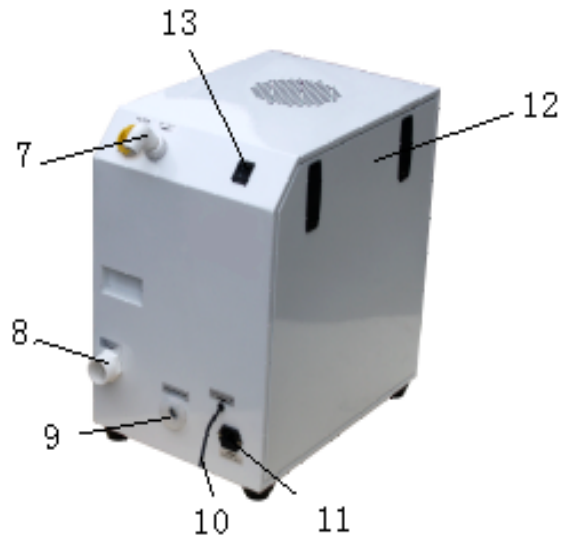

1. Filter	2. Drain bottle	3. Case	4. Bottom feet
5. Ring blower	6. Electric board	7. Air inlet	8. Air outlet
9. Water outlet	10. Control line	11. Power Plug	12. Lock
13. Power switch			

3.1.2 DS7501CS structure

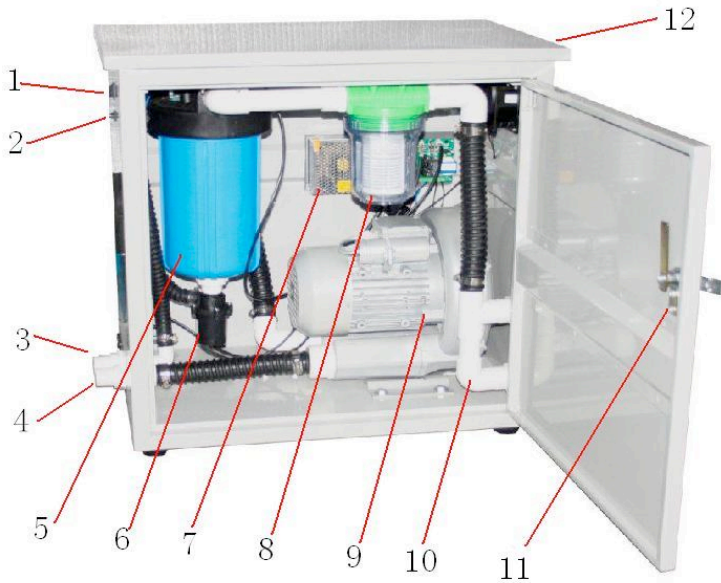

strumentidentali.it

1.Power switch	2.Overload protector	3. Water outlet	4. Air outlet
5. Drain bottle	6.Drain pump	7. DC power	8. Filter
9. Ring blower	10.Air Inlet	11.Lock	12. Control line

3.1.3 DS3701CS-1 structure

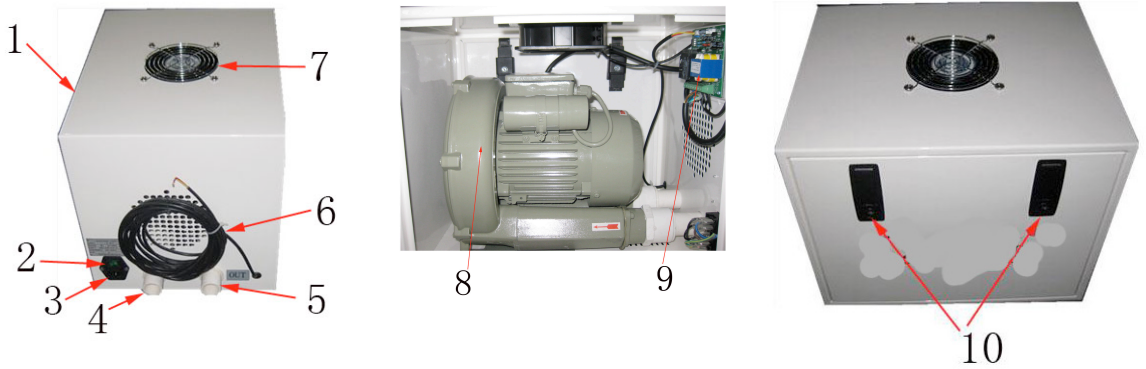

1.Case	2.Power switch	3.Power socket	4.Air intake
5.Air outlet	6.Control line	7.Fan	8.Ring blower
9.Electric board	10.Lock		

strumentidentali.it

3.1.3 DS3701M、DS2501M structure



1. HIGH VOLUME EVACUATION	2. COVER	3. SALIVA EJECTOR	4. RACK
5. FILTER	6. BACK COVER	7. CASE	8. POWER SWITCH
9. POWER SOCKET	10. FAN	11. WHEEL	12. REINFORCED PLASTIC TUBE
13. ELBOW	14. DRAIN WATER EXIT		

3.2 Procedures of installation

3.2.1 Installation:

(1) Check after unpacking

Ensure that every component of the unit is intact after opening the box and check that spare parts are intact according to packing list. In case of doubt, please contact our company or local agent.

(2) Precautions of installation

The electric units should be installed by competent person only.

(3) Condition of installation

(a) Ambient temperature: 5℃~40℃

(b) The unit should be well positioned to ensure there is an adequate airflow around the machine.

(4) Method of installation

(a) Install the equipment close to treatment unit, and ensure mounting level of suction unit lower than treatment units. Please note that the door of suction unit should not be opened freely for safety.

(b) The suction unit should be well situated to ensure it has 25cm space free of obstacle around two sides of case.

(5) Specifications of connecting pipes

(a) DS3701CS Pipe connects suction unit with dental treatment unit:

Material: PPR or PVC

Inner diameter: DS3701CS、DS3701M、DS2501M (φ20), DS3701CS-1、DS7501CS (φ32)。

Length: ≤5m

Height of installation: 0.5m higher than bottom of suction unit

(b) Pipe connects air outlet with outdoor pipeline:

Material: PPR or PVC

Inner diameter: φ32

(c) Pipe connects drain water exit with outdoor waste processing pipeline:

Material: PPR or PVC

Inner diameter: DS3701CS、DS3701M、DS2501M (φ20), DS3701CS-1、DS7501CS (φ32)。

Height of installation: lower than bottom of suction unit

(6) Electrical requirements

Power: when install the power socket; please ensure the power voltage consistent with the rated voltage and frequency which this unit required.

3.2.2 Test

Take up saliva ejector from clip-on instrument holder of dental treatment unit, and the suction unit will start automatically. During the first testing or using, please put saliva ejector into clean water, and check whether water can be drained from drain water exit. Then put saliva ejector back to clip-on instrument holder, the power of suction unit will shut off. Please note that suction unit will continue to work for 5~10 seconds to clean the foreign objects inside tubes because of time delay unit installed in the electric board.



Warning: To avoid unsteady voltage, please do not use the power plug together with other electric equipment.

4. Functions of main parts

4.1 Filter: mainly used to separate solid particles(such as teeth fragments, silver amalgam particles) from dirty blood and oral secretion, as well as protecting environment since they will be collected and dealt with before being pumped.(please clean solid particles inside the filter regularly)

4.2 Drain bottle: used to separate the air from dirty blood and oral secretion, and then collect the left mixture. When mixtures inside bottle reach the named height, the units shut off automatically, and restart as being drained.

5. Maintenance

1. Clean the suction tubes everyday by sucking clean water twice (1 liter each time) after use.

2. Clean the drain bottle and filter weekly.

3. Clean the tubes every three months.

6. Split-up drawing of ring blower

001 Wind cover	006 Bushing block	011 Bearing	016 Connector
002 Screw	007 Wind barrel	012 Electric motor	017 Foot
003 Spring-pad	008 Bearing	013 Rubber gasket	
004 Impeller plate	009 Bearing block	014 Core	
005 Impeller	010 Rotor	015 Flue pipe	

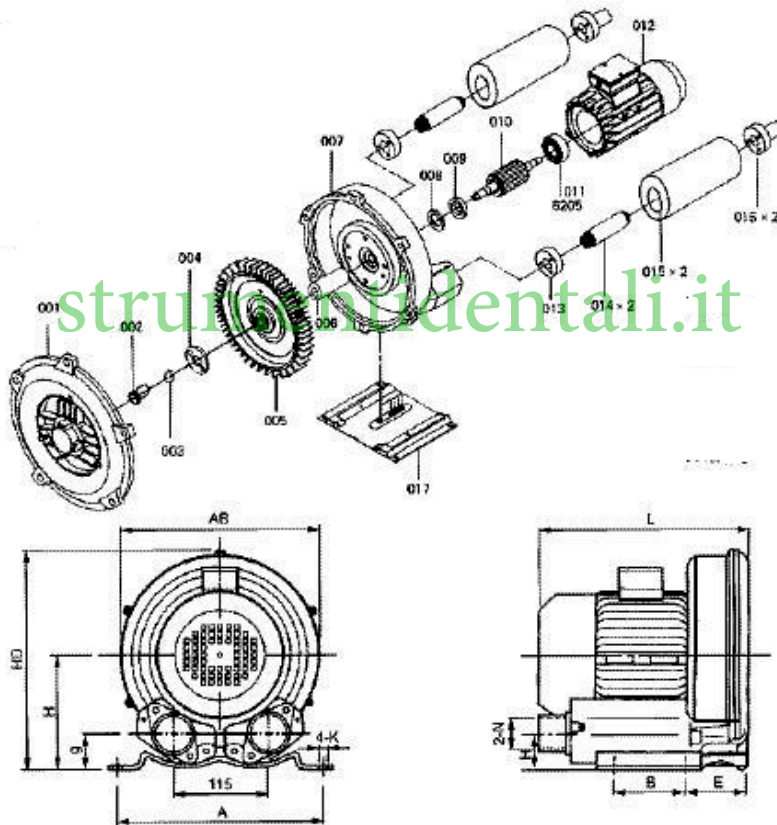

7. Troubleshooting

	Problem	Reason	Check
1	Cannot work with very weak suction	The air inlet is blocked	Check the air inlet
		The filter is blocked	Check the filter
2	Can not start up the compressor with the compressor shaking and noisy	The power pressure is too low.	Make the pressure rise or use manostat.
3	The pump cannot work.	The power is not switched on	Check if the power supply is connected correctly
		A fuse is blown	Check if the fuse is blown
		The overload protector is bounced	Check if the overload protector is bounced
		The wire to the power supply has fallen off or an electronic component is loose	Check the patch board and the electric connection of the compressor

8. Working principle overview

Ring blower working principle: Ring blower's impeller contains numerous blades in its edge and it is special designed for a high air pressure. When the impeller is rotating, air between the impeller would be accelerated along the direction of the fan blades and due to rotating movement, after air enters outside air layer, it comes back to the base of the fan blades due to the effect of the differential pressure, the cycle will repeat several times to make the air run spirally so as to increase the pressure. The air will expel quickly because of the pressure there bigger than the pressure in the system when the air runs through the outlet.

Operating principle: Connect the suction unit with dental treatment unit, take up saliva ejector from clip-on instrument holder of dental treatment unit, and the suction unit will start automatically to suck foreign objects attached with germina (such as oral secretion and dirty blood) into filter, the filter will separate solid

particles(such as teeth fragments, silver amalgam particles) from dirty blood and oral secretion(please clean solid particles inside the filter regularly).The filtered dirty blood and oral secretion will be sucked into drain bottle, the air and water separator will separate the air from dirty blood and oral secretion to ensure the air offered for ring blower is clean and prevent the impellers from corrosive damage.

9. Safety precautions

1. When dental suction units working, please make sure that there will be no goods can be touched the air compressor.
2. Clean the filter regularly.
3. To change the electrical parts timely, but must turn off the power.
4. When to clean and maintenance the dental units, please to turn off the power.
5. After setting up the suction units, do not move the machine too often, avoid to affecting its working conditions.
6. To forbid the unprofessional person to use the air compressor, avoiding to operating wrong.
7. When to maintenance the suction units, it must be some person who is very qualified.
8. Do not let the olds, children come into contact with the compressor to avoid resulting harm.
9. When to use the suction units under knowing there will be result of harm, to forbid using the suction units.
10. When the dental suction units are retired, the capacitor and electrical components should be available to the local law and regulation.

strumentidentali.it

10. Drawing of air connection and electrical circuit

10.1 DS7501CS air connection

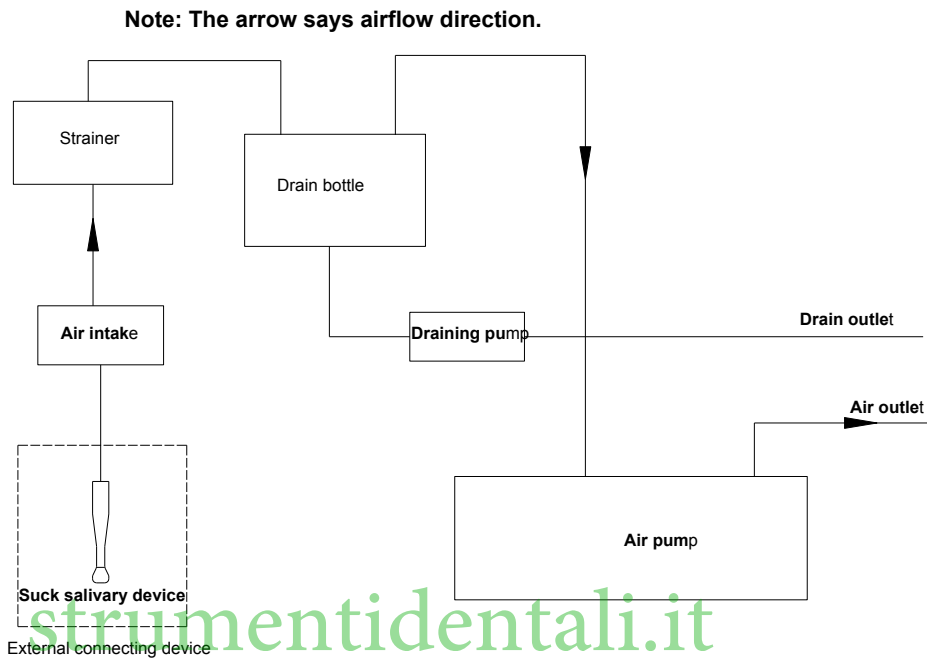

10.2 DS3701CS air connection

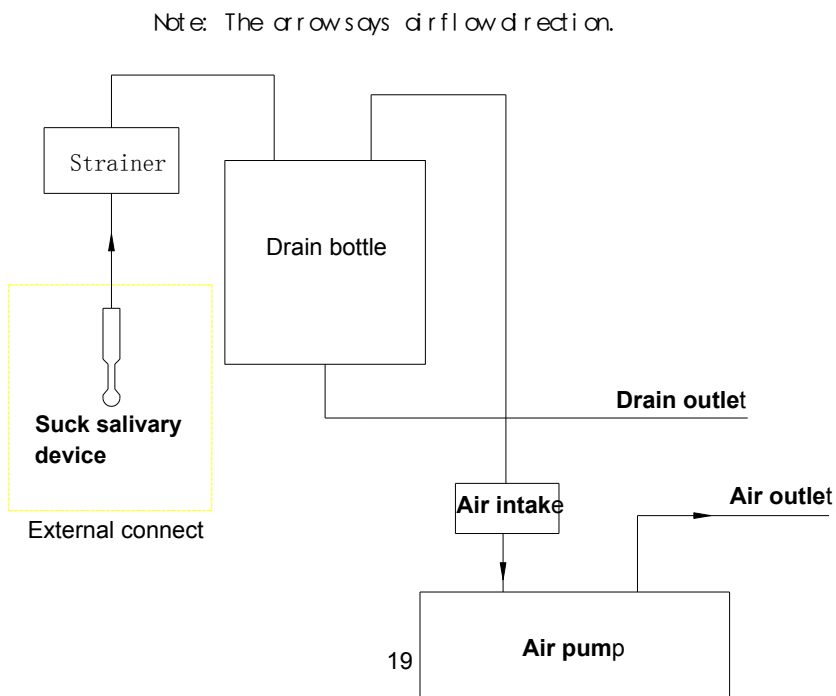

10.3 DS3701CS-1 air connection

Note: The arrow says airflow direction.

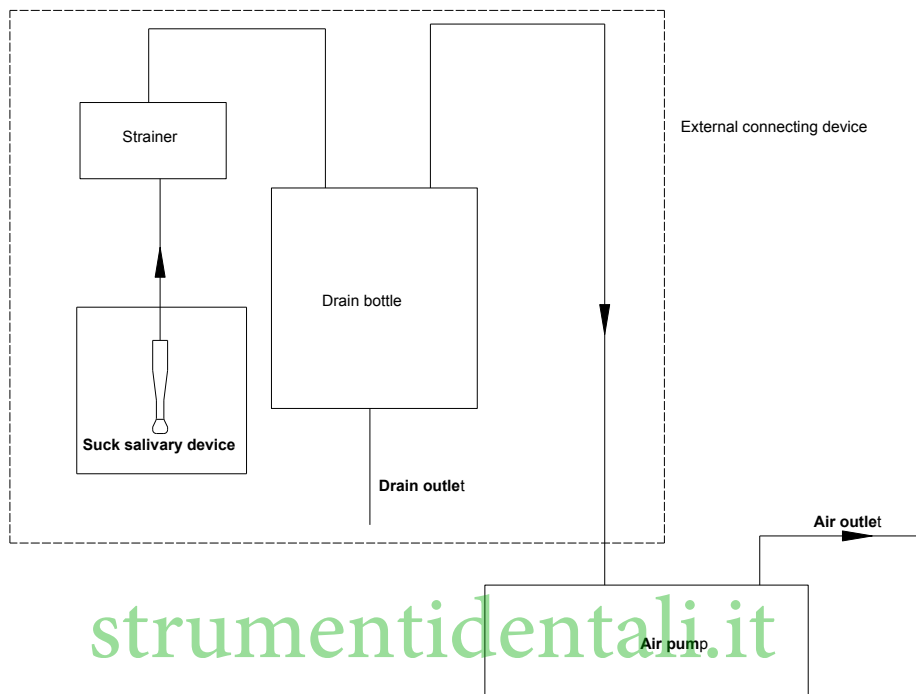

10.4 DS3701M, DS2501M air connection

Note: The arrow says airflow direction.

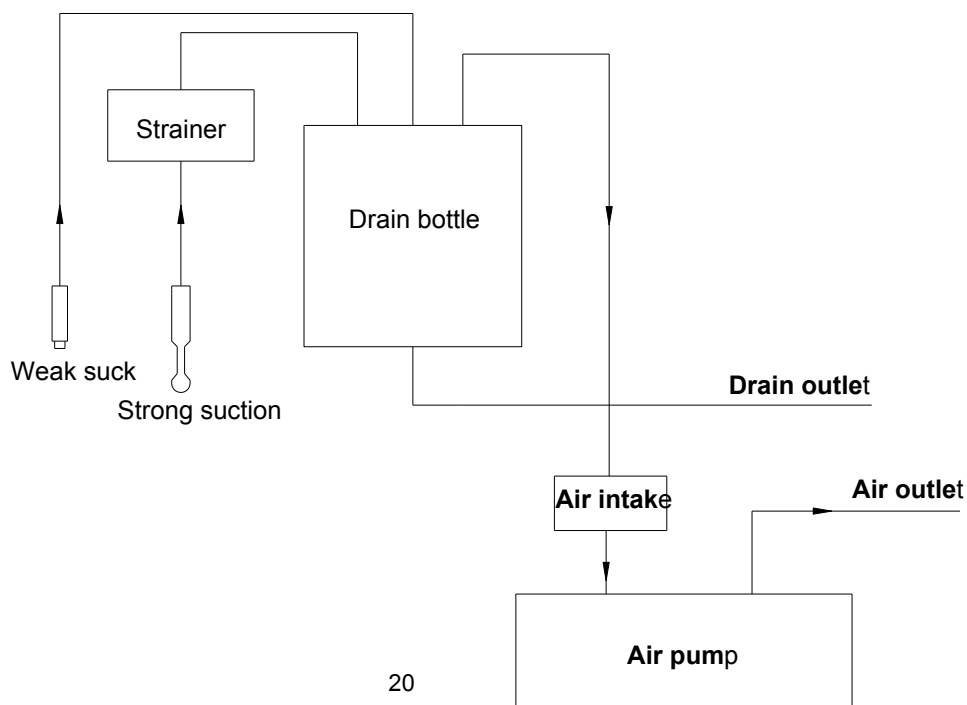

10.5 DS7501CS electrical schematic diagram

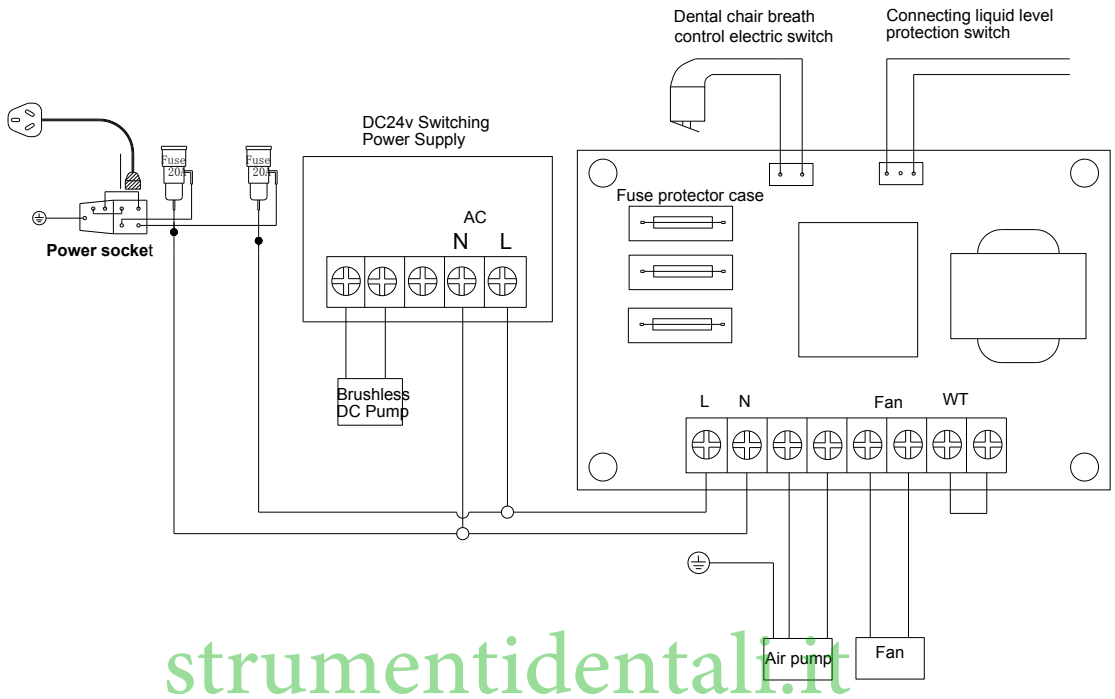

10.6 DS3701CS, DS3701CS-1 electrical schematic diagram

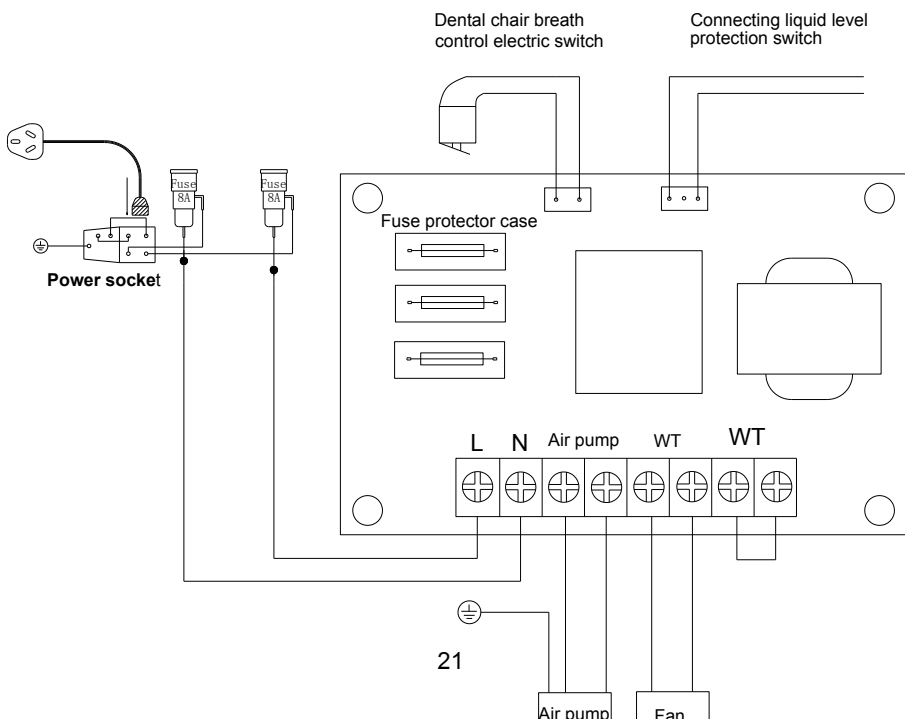

10.7 DS370M、DS2501M electrical schematic diagram

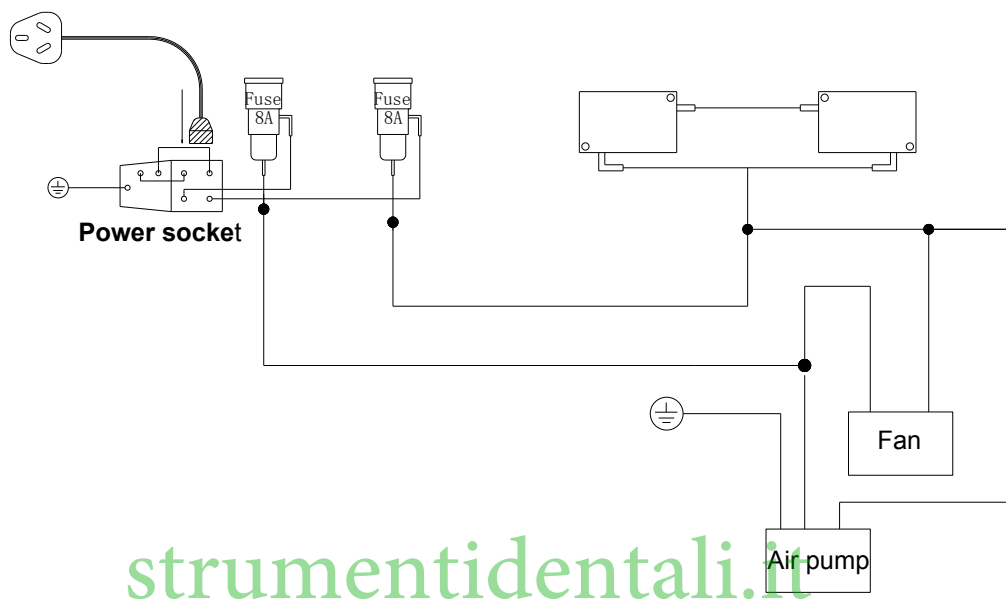

11. External mark and content

1. Following are concluded in external packing:

Product name: Medical Suction Unit

2. Model: DU

3. Standard NO.:

4. Product registration NO.:

5. Factory name: Jiangsu Dynamic Medical Technology Co.,Ltd

Factory address: No.108 Xingpu Road, Lujia Town, Kunshan, City,
Jiangsu, 215331 People's Republic of China

6. Packing dimension:

External size: L×W×H

- G.W: kg
- N.W: kg
- 7. Brand:

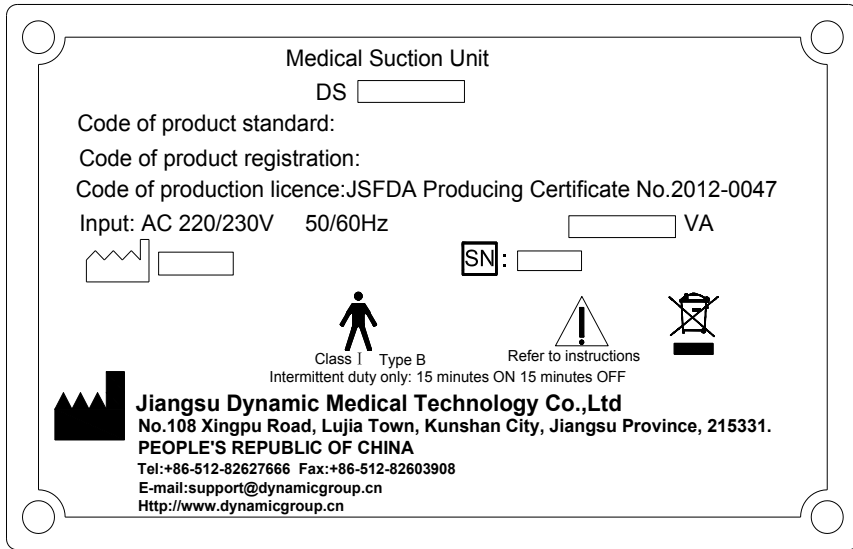

strumentidentali.it

8. Graph label:

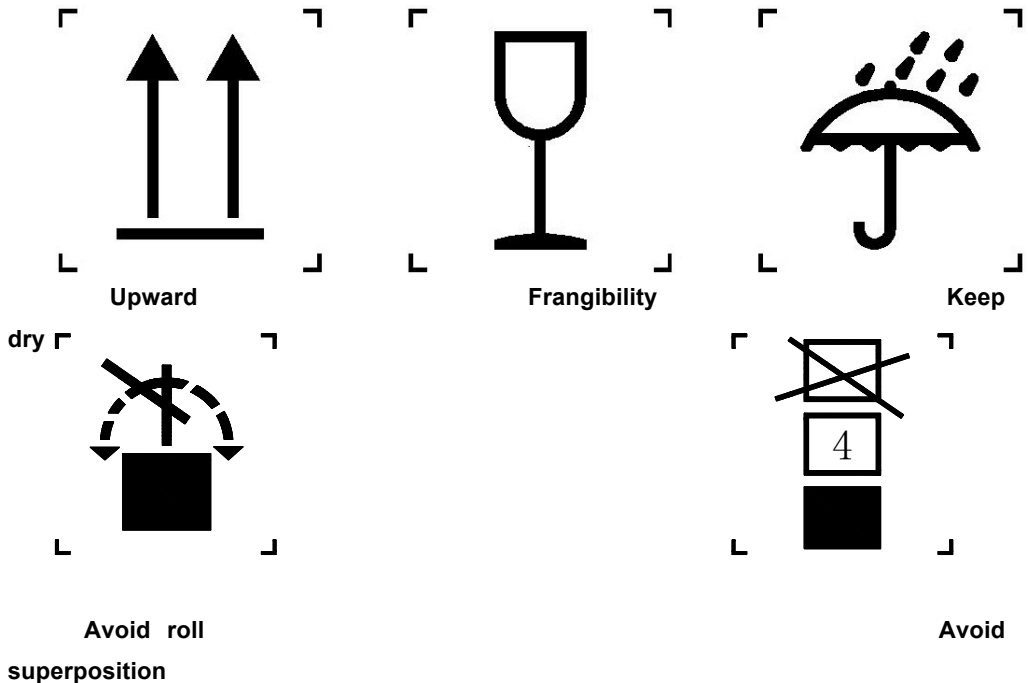

12. Thirteen : Packing list

No	Name	Quantity	Remark
1	Suction unit	1 pc	DS3701CS、DS3701CS-1、DS7501CS、 DS3701M、DS2501M
2	Spring pipe 3mm(Diameter: 32m)	1 pc	DS7501CS、DS3701CS-1
3	Metal hoop $\Phi 32$	6 pcs	DS7501CS、DS3701CS-1
4	Spring pipe 3mm(Diameter: 20m)	1 pc	DS3701CS、DS3701M、DS2501M
5	Metal hoop $\Phi 20$	6 pcs	DS3701CS、DS3701M、DS2501M
6	Power supply wire	1 pc	DS3701CS、DS3701CS-1、DS7501CS、 DS3701M、DS2501M
7	Fuse	3 pcs	DS3701CS、DS3701CS-1、DS7501CS、 DS3701M、DS2501M
8	Operation manual	1 pc	DS3701CS、DS3701CS-1、DS7501CS、 DS3701M、DS2501M

851 South Lawson Street
 City of Industry CA 91748
 800-560-8222 – 626-810-4245

www.tpcdental.com

strumentidentali.it